

NS12-9

12V9Ah / 20hr



Introduction

EPI NS UPS (4.5Ah-28Ah) series is designed for standby use with 5-year design life in float service. The series battery is featured of high consistency, excellent performance and reliable standby service life. It is widely applied in UPS/EPS, medical equipment, emergency light and security system.

Battery Features

- Outstanding consistency in Standby system
- Stable quality and high pass rate
- 5 years design life in floating condition
- Low self-discharge rate

Electrical Specification

Design floating Life @ 20°C (68°F)	5 years
Nominal Capacity @ 25°C /77°F	
20 hour rate 0.45A to 1.75Vpc	9.0 Ah
10 hour rate 0.85A to 1.75Vpc	8.5 Ah
Internal Resistance	
(Fully charged battery @ 25°C /77°F)	16 mΩ
Max. Discharge Current @ 25°C /77°	135 A (5S)
Charge Methods: Constant voltage charge @ 25°C /77°F	
Cycle Use	14.7 ~ 14.9V
Max. Curren	2.1 A
Standby Use	13.6 - 13.8V
Operating Temperature Range	
Discharge	-15 ~ 50°C
Charge	0 ~ 50°C
Storage	-15 ~ 50°C
Recommended Operating Temp	15 ~ 25°C
Self-Discharge	
3% of capacity declined per month @ 20°C (68°F).	

Battery Picture & Terminal Layout

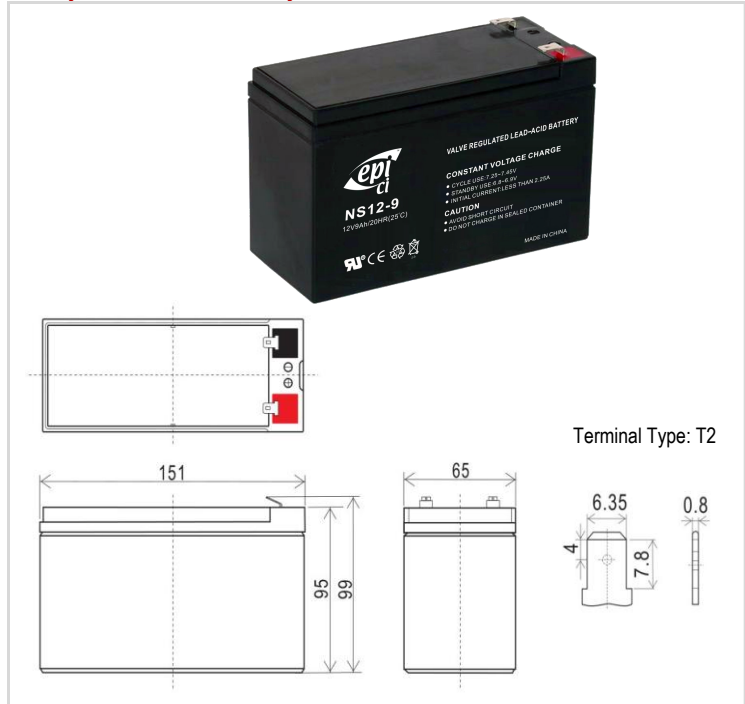

Dimension & Weight

Length	Dimension (± 2mm)			Weight (± 2%)
	Width	Height	Total Height	
151 mm	65 mm	95 mm	99 mm	2.52 kg
5.9 inch	2.6 inch	3.7 inch	3.9 inch	5.6 lbs

Typical Applications

- UPS & EPS
- Power Utility
- Security Power Supply
- Electrical Toys

Constant Current Discharge (Amperes @ 25°C /77°F)

V/cell	10min	15min	20min	25min	30min	35min	40min	45min	50min	55min	1hr	2hr	3hr	4hr	5hr	10hr	20hr
1.60	20.46	15.62	13.34	11.07	8.80	8.14	7.48	6.82	6.16	5.50	4.84	2.81	2.13	1.87	1.62	0.88	0.46
1.65	19.59	14.96	12.79	10.63	8.47	7.84	7.22	6.60	5.97	5.35	4.72	2.75	2.07	1.83	1.59	0.87	0.46
1.70	18.73	14.30	12.24	10.18	8.13	7.54	6.96	6.37	5.78	5.20	4.61	2.68	2.02	1.79	1.56	0.86	0.45
1.75	17.87	13.64	11.69	9.75	7.81	7.26	6.71	6.15	5.60	5.05	4.50	2.62	1.96	1.75	1.54	0.85	0.45
1.80	17.00	12.98	11.16	9.33	7.51	6.99	6.47	5.95	5.43	4.91	4.39	2.55	1.89	1.70	1.51	0.83	0.44

Constant Power Discharge (Watts/cell @ 25°C /77°F)

V/cell	10min	15min	20min	25min	30min	35min	40min	45min	50min	55min	1hr	2hr	3hr	4hr	5hr	10hr	20hr
1.60	39.19	29.92	25.44	20.97	16.50	15.40	14.30	13.20	12.10	11.00	9.90	5.75	4.56	3.76	2.95	1.79	0.98
1.65	37.60	28.71	24.42	20.13	15.84	14.77	13.71	12.64	11.58	10.51	9.45	5.49	4.45	3.67	2.90	1.78	0.95
1.70	36.02	27.50	23.43	19.36	15.29	14.24	13.19	12.14	11.09	10.04	9.00	5.23	4.33	3.59	2.85	1.76	0.93
1.75	34.72	26.51	22.55	18.59	14.63	13.61	12.60	11.59	10.57	9.56	8.55	4.97	4.20	3.50	2.79	1.74	0.93
1.80	33.14	25.30	21.56	17.82	14.08	13.10	12.13	11.15	10.17	9.20	8.22	4.78	4.06	3.39	2.72	1.72	0.88

*The mentioned data are derived from of sample test result, for reference only.

Subject to revision without notice. Please contact our sales representatives for latest version.

Web: www.epi-ups.com | Email: sales@epi-ups.com

NS12-9

12V9Ah / 20hr



Graphs

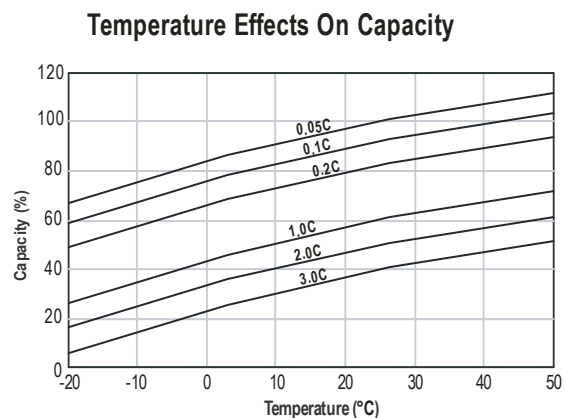
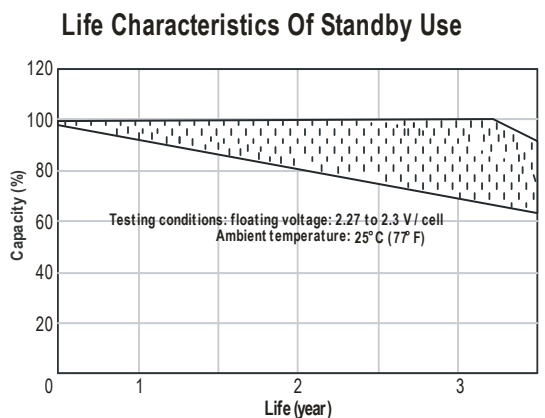
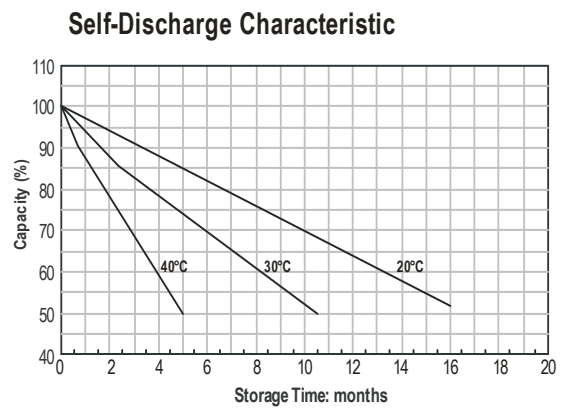
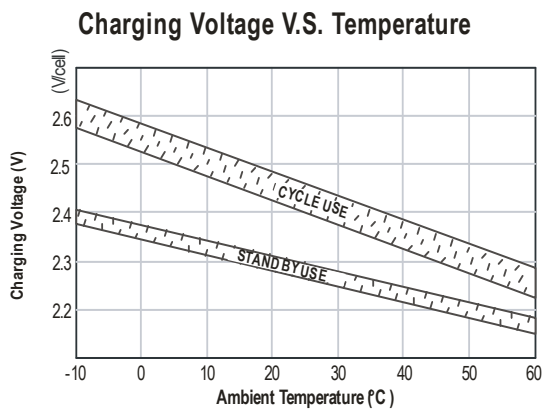
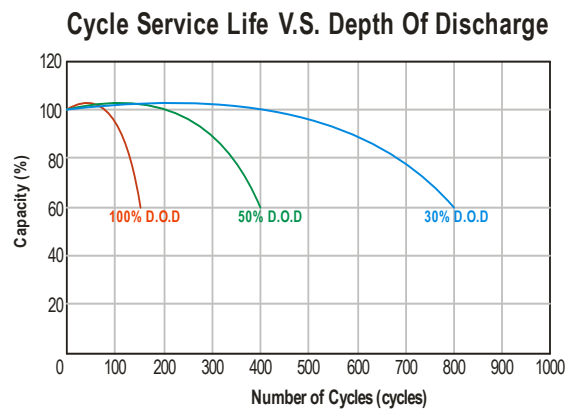
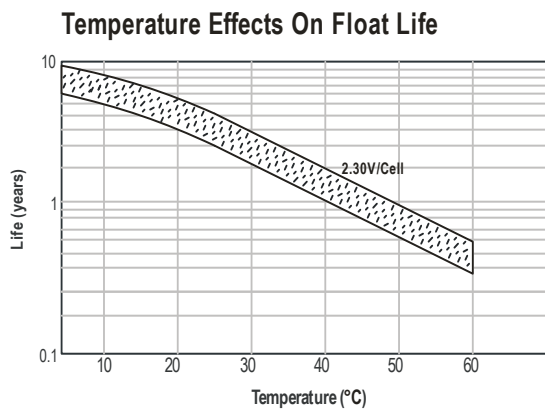
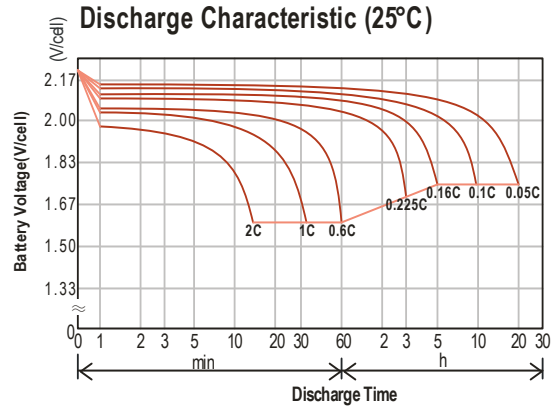
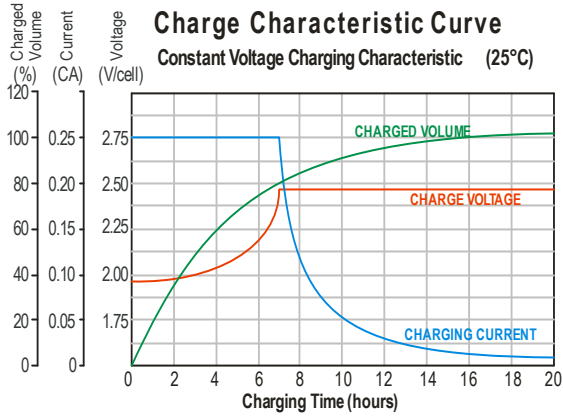

Subject to revision without notice. Please contact our sales representatives for latest version.